



ConnectCore 8M Nano

Development Board

Hardware Reference Manual

Revision history—90002385

Revision	Date	Description
1P	January 2020	Initial release.
2P	October 2020	Update block diagram, create "Storage interfaces" section, and extend Gigabit Ethernet section.
3P	November 2020	Confirm support for booting from microSD, add new "power architecture configuration" section.
A	March 2021	Add RS-485 note and J54 connector.
B	October 2021	Added safety statements.
C	February 2022	Corrected UART console port and J17 connector pin data.
D	April 2022	Corrected capacitance value of supercap.

Trademarks and copyright

Digi, Digi International, and the Digi logo are trademarks or registered trademarks in the United States and other countries worldwide. All other trademarks mentioned in this document are the property of their respective owners.

© 2020-2023 Digi International Inc. All rights reserved.

Disclaimers

Information in this document is subject to change without notice and does not represent a commitment on the part of Digi International. Digi provides this document "as is," without warranty of any kind, expressed or implied, including, but not limited to, the implied warranties of fitness or merchantability for a particular purpose. Digi may make improvements and/or changes in this manual or in the product(s) and/or the program(s) described in this manual at any time.

Warranty

To view product warranty information, go to the following website:

www.digi.com/howtobuy/terms

Customer support

Gather support information: Before contacting Digi technical support for help, gather the following information:

- Product name and model
- Product serial number (s)
- Firmware version
- Operating system/browser (if applicable)
- Logs (from time of reported issue)
- Trace (if possible)
- Description of issue
- Steps to reproduce

Contact Digi technical support: Digi offers multiple technical support plans and service packages. Contact us at +1 952.912.3444 or visit us at www.digi.com/support.

Feedback

To provide feedback on this document, email your comments to

techcomm@digi.com

Include the document title and part number (ConnectCore 8M Nano Development Board Hardware Reference Manual, 90002385 D) in the subject line of your email.

Contents

About the ConnectCore 8M Nano Development Board

Features and functionality	5
Safety instructions	6
Block diagram	8
Placement and connectors	9

Interfaces

Power	14
DC-in connectors	14
Power architecture configuration	14
Coin cell/Supercap	14
Battery connector	15
Power and reset buttons	15
System boot	15
Debug	16
JTAG	16
SWD	16
Console ports	17
USB recovery	17
Communication	18
Gigabit Ethernet	18
RS-485	18
CAN	19
USB Host	19
Mini PCIe	19
XBee	19
Multimedia	20
HDMI, LVDS, and MIPI displays	20
MIPI-CSI camera	21
Audio	22
Storage interfaces	23
MicroSD	23
User interfaces	23
User LED	23
User button	23

About the ConnectCore 8M Nano Development Board

The Digi ConnectCore 8M Nano Development Board is a system-on-module (SOM) development kit that streamlines the prototyping of a wide range of industrial and medical applications.

Built on the i.MX 8M Nano processor with power-efficient quad ARM® Cortex®-A53 and Cortex-M7 cores, Digi ConnectCore 8M Nano combines pre-certified wireless connectivity (802.11 a/b/g/n/ac and Bluetooth® 5) with Digi TrustFence® and Digi Microcontroller Assist™.

Features and functionality

- Power:
 - 5 V input power jack connector
 - Battery connector
 - Coin cell connector
 - On-board supercap supporting RTC functionality
 - Power and reset buttons
- Boot source configuration: eMMC, USB, microSD
- Debug:
 - Standard IEEE 1149.1 JTAG interface
 - Single Wired Debug (SWD) interface for the on-module Digi Microcontroller Assist™ (MCA)
 - USB console
 - USB for system-on-module recovery
- Multimedia:
 - HDMI display*.
 - LVDS display with backlight control and I2C touch interface*.
 - MIPI-DSI*.
 - MIPI-CSI camera supporting two data lanes. Two additional data lanes are available in the expansion connector.
- Storage:
 - microSD card slot
- Communication:
 - Gigabit Ethernet 10/100/1000 with RJ-45 connector
 - x2 USB host (dual type-A)
 - x5 GPIOs

- CAN FD (through SPI interface)
- RS-485
- PCI Express Mini Card slot supporting half- and full-size cards, with USB connection and micro-SIM slot support
- Audio interfaces:
 - x1 3.5 mm headphone jack
 - x1 3.5 mm microphone jack
 - x2 speaker outputs
 - x1 line-out output
 - x2 line-in inputs
- x2 XBee sockets, one supporting XBee cellular
- x2 SMA antenna connectors, one for the on-module antenna and another for the Mini PCIe card
- User interfaces:
 - x2 user buttons
 - x3 user LEDs
- Dimensions:
 - 210 x 130 mm

Note * Only one display interface can be enabled at a time.

Safety instructions

- The ConnectCore 8M Nano development board cannot be guaranteed operation due to the radio link and so should not be used for interlocks in safety critical devices such as machines or automotive applications.
- The ConnectCore 8M Nano development board has not been approved for use in (this list is not exhaustive):
 - nuclear applications
 - explosive or flammable atmospheres
- There are no user serviceable components inside the ConnectCore 8M Nano development board. Do not remove the shield or modify the ConnectCore 8M Nano in any way. Modifications may exclude the development board from any warranty and can cause the ConnectCore 8M Nano to operate outside of regulatory compliance for a given country, leading to the possible illegal operation of the radio.
- Use industry standard ESD protection when handling the ConnectCore 8M Nano development board.
- Take care while handling to avoid electrical damage to the PCB and components.
- Do not expose ConnectCore 8M Nano development board to water or moisture.
- Use this product with the antennas specified in the ConnectCore 8M Nano development board user guides.

- The end user must be told how to remove power from the ConnectCore 8M Nano development board or to locate the antennas 20 cm from humans or animals.

Block diagram

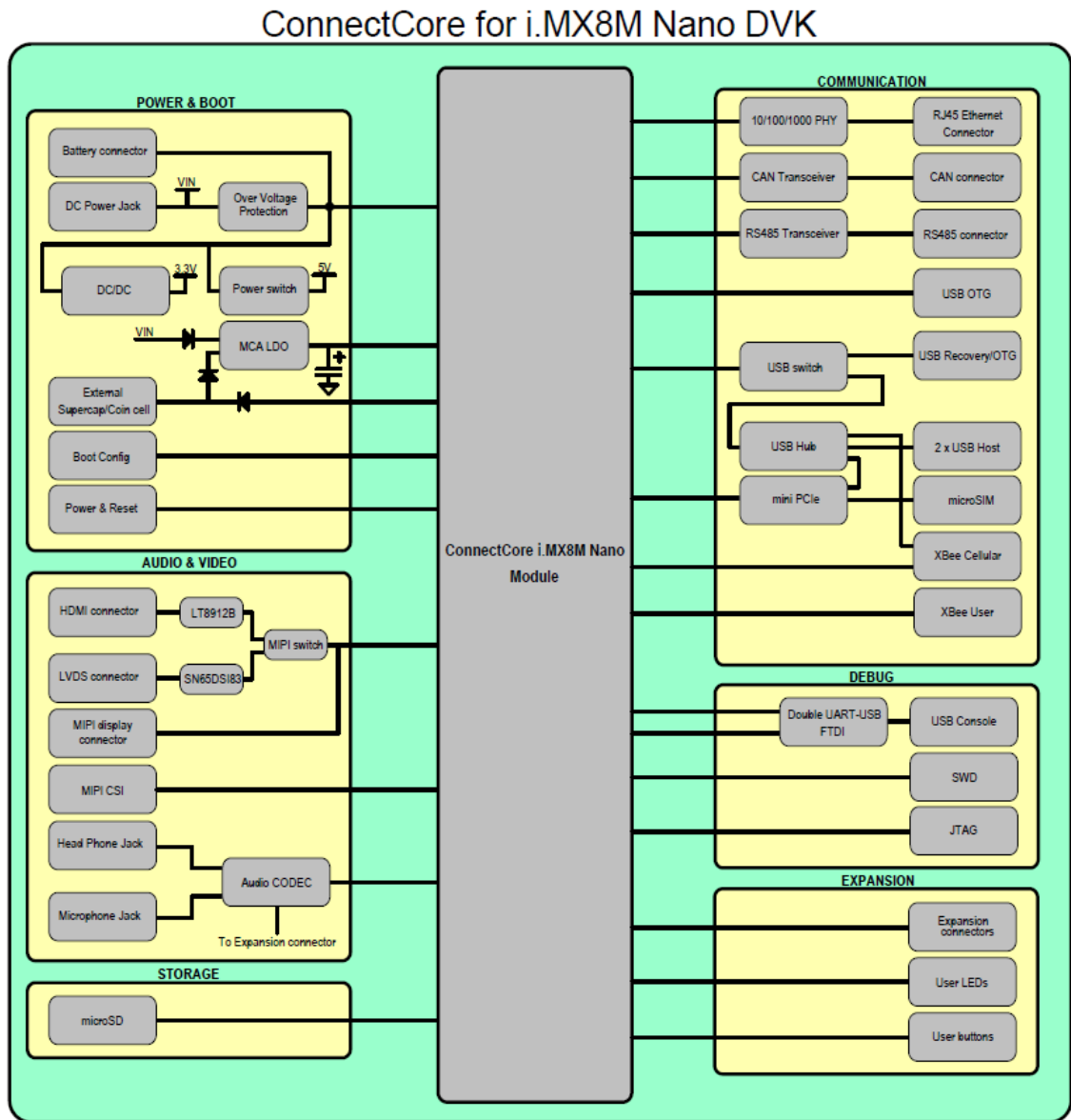

Placement and connectors

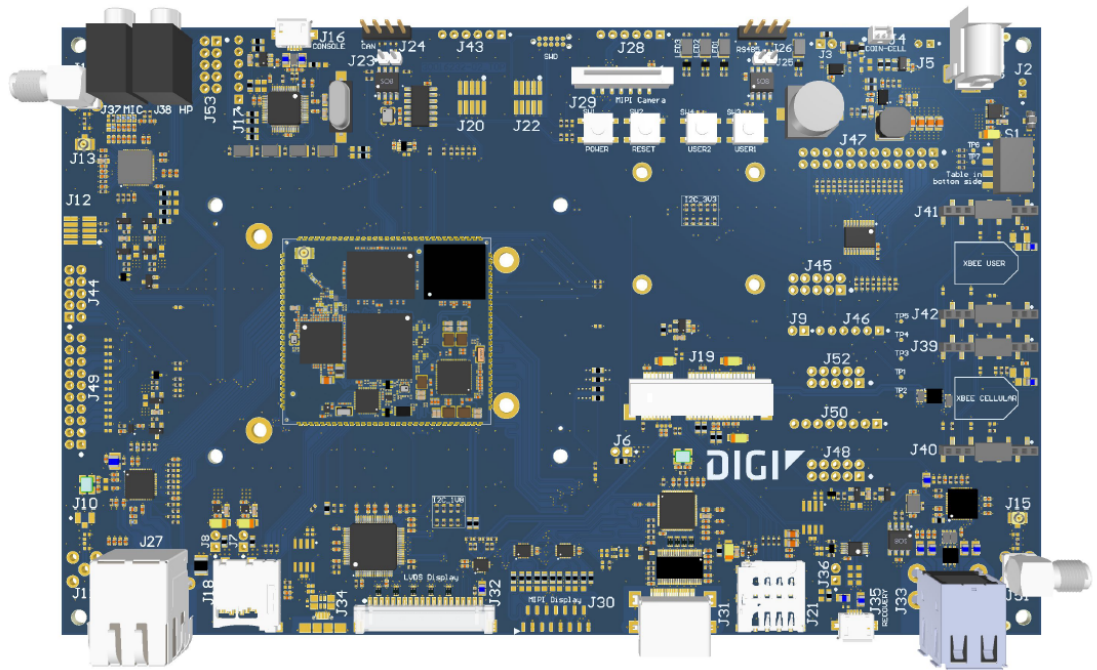

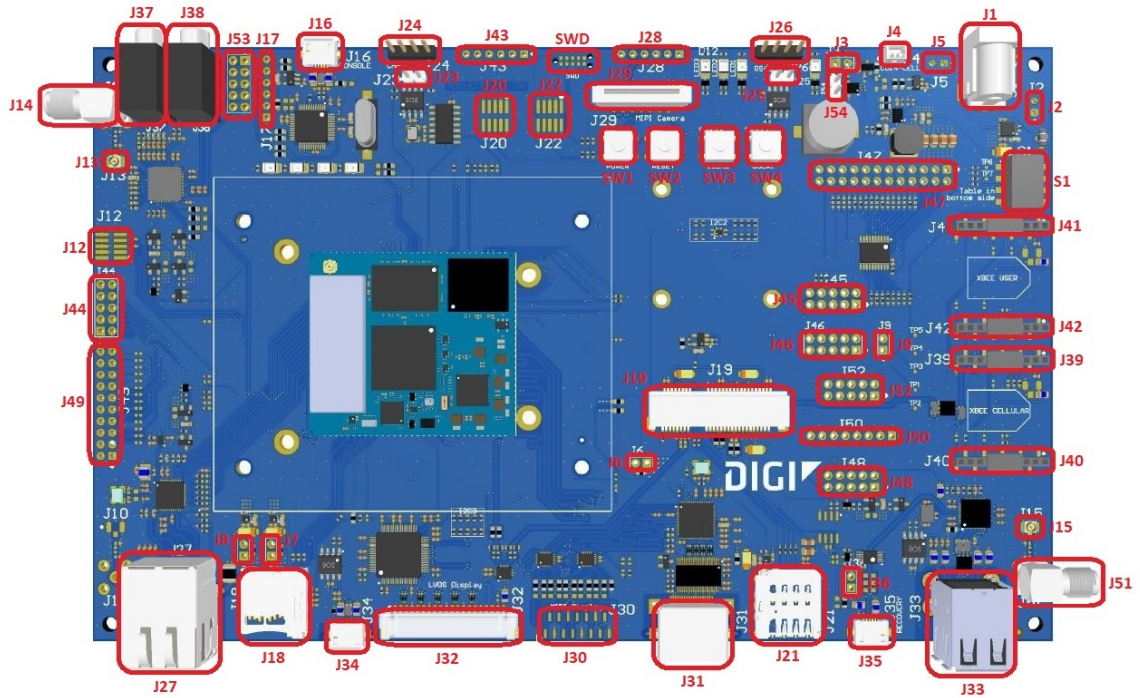

Connector	Interface	Manufacturer	Manufacturer Part Number
J1	5 V power-in jack	Bobbintron	SCD443CCS011B00G
J2	Alternative 5 V power-in	TE Connectivity	640456-2
J3	MCA power consumption	-	-
J4	Coin-cell	Molex	53047-0210
J5	Battery connector	TE Connectivity	640456-2
J6	SOM power consumption	-	-
J7	3V3 DVK power consumption	-	-
J8	1V8 DVK power consumption	-	-
J9	Debug	-	-
J10	u.FL antenna connector	Hirose	U.FL-R-SMT(10)
J11	SMA antenna connector	Bobbintron	SMA A700T
J12	Wireless MAC JTAG	Samtec	FTSH-105-01-F-DV

Connector	Interface	Manufacturer	Manufacturer Part Number
J13	u.FL antenna connector	Hirose	U.FL-R-SMT(10)
J14	SMA antenna connector	Bobbintron	SMA A700T
J15	u.FL antenna connector	Hirose	U.FL-R-SMT(10)
J16	Console (USB)	Kycon	KMMX-ABSMT5SG-30TR
J17	Console (TTL)	-	-
J18	MicroSD	Amphenol	GTFP08431BEU
J19	Mini PCIe	Foxconn	AS0B226-S68N-7F
J20	i.MX8M JTAG	Samtec	FTSH-105-01-F-DV
J21	MicroSIM	Molex	78727-0001
J22	MCA SWD	Samtec	FTSH-105-01-F-DV
J23	CAN termination resistor	-	-
J24	CAN	Samtec	TSW-104-14-G-S
J25	RS485 termination resistor	-	-
J26	RS485	Samtec	TSW-104-14-G-S
J27	Ethernet	Xmultiple	XMG-J1B2211NPA-1-DIG
J28	MIPI camera extension	-	-
J29	MIPI camera	Amphenol	SFW15S-2STE1LF
J30	MIPI display	Amphenol	SFW15S-2STE1LF
J31	HDMI	Adam Tech	HDMI-S-RA-TSMT
J32	LVDS	Hirose	DF14A-20P-1.25H(25)
J33	USB Host	Excel Cell Electronic	ESB01211000Z
J34	USB OTG	Kycon	KMMX-ABSMT5SG-30TR
J35	USB recovery	Kycon	KMMX-ABSMT5SG-30TR
J36	Force USB recovery	-	-
J37	Microphone input	CUI Devices	SJ1-3533NG
J38	Headphones output	CUI Devices	SJ1-3533NG
J39-J40	XBee Cellular	Samtec	SMM-110-02-F-S-P-TR
J41-J42	XBee user	Samtec	SMM-110-02-F-S-P-TR
J43	Control signals	-	-
J44	Wireless signals	-	-

Connector	Interface	Manufacturer	Manufacturer Part Number
J45	UARTs	-	-
J46	GPIOs	-	-
J47	SAI1	-	-
J48	I2C	-	-
J49	Wireless signals	-	-
J50	Clocks	-	-
J51	SMA antenna connector	Bobbintron	SMA A700T
J52	Power rails	-	-
J53	Audio	-	-
J54	Supercap	-	-

Interfaces

The following interfaces are available on the ConnectCore 8M Nano:

Power	14
System boot	15
Debug	16
Communication	18
Multimedia	20
Storage interfaces	23
User interfaces	23

Power

DC-in connectors

The input voltage of the ConnectCore 8M Nano Development Board is 5 V. You can use one of two connectors to power the entire system. Note that you can only enable one at a time.

- DC-in power jack connector
- J2, a 2-pin, 2.54 mm pitch connector:

Pin	Signal name	Description
1	VIN	5 V power supply rail
2	GND	Ground

An overvoltage circuit protects the board from overvoltage and overcurrent events. Downstream from these input power protections, there are three regulators/switches for powering both the SOM and the carrier board circuitry:

- MCA LDO (U2): This regulator generates the 3.3 V that powers the on-module MCA.
- 5 V Load switch: A 5 V load switch controls the power delivery to some interfaces (CAN, HDMI, LVDS).
- 3.3 V On-board regulator (U4): This buck regulator powers the XBee and PCIe sockets.

Power architecture configuration

SOM input supply	Power rail connected to	Nominal operating voltage
VSYS	VIN (input supply of the board)	5V
VCC_MCA	Dedicated 3.3V regulator	3V (considering forward diode)
VDD_USDHC2	MUX_3V3_1V8	3.3V
VDD_ENET	1V8	1.8V
VDD_UART	3V3	3.3V

Coin cell/Supercap

A 470 mF supercap supports RTC applications. Connector J4 on the board is included for attaching a coin-cell:

Pin	Signal name	Description
1	VCC_RTC	Power supply for RTC
2	GND	Ground

Note Coin-cell charger support will depend on the version of the SOM soldered to the Development Board.

Battery connector

The development board includes one battery connector (J5):

Pin	Signal name	Description
1	VSYS2	Battery power supply
2	GND	Ground

Power applied to this power supply feeds the part of the ConnectCore 8M Nano SOM that supports battery applications.

Power and reset buttons

One power button (SW1) and one reset button (SW2) are included on the development board. These buttons support the following functionality:

Button	Board status	Power button action	Response
SW1	OFF	Short press	Power on
	ON or SLEEP	Long press for 5 seconds	Power off
	SLEEP	Short press	Wake-up
	ON	Short press	Sleep
SW2	-	Short press	Reset

System boot

The ConnectCore 8M Nano supports different boot modes (see the [ConnectCore 8M Nano Hardware Reference Manual](#) for detailed information). The development board supports these boot modes, but some require changes to the populated components.

A quadruple switch (S1) allows you to easily swap between four different boot modes. Two of the four switches are used for this purpose:

SW1.2	SW1.1	Description
Open	Open	Boot from eMMC0
Open	Close	Boot from fuses
Close	Open	Boot from microSD
Close	Close	Serial downloader

Debug

JTAG

A JTAG connector (J20, not populated by default) is available on the development board for accessing the JTAG interface of the CPU:

Pin	Signal name	Description
1	1V8_SOM_EXT	1.8 V power supply
2	JTAG_TMS	Mode select line
3	GND	Ground
4	JTAG_TCK	Clock line
5	GND	Ground
6	JTAG_TDO	Data output line
7	NC	Not connected
8	JTAG_TDI	Data input line
9	GND	Ground
10	POR_B	Reset line

SWD

The development board provides two options for programming and debugging the ConnectCore 8M Nano on-module MCA:

- J22, a 10 pin (2x5), 1.27 mm pitch connector:

Pin	Signal name	Description
1	VCC_MCA	3.3 V supply voltage of the MCA
2	SWD_DIO	Data I/O line
3	GND	Ground
4	SWD_CLK	Clock line
5	GND	Ground
6	NC	Not connected
7	NC	Not connected
8	NC	Not connected
9	GND	Ground
10	SYS_RESET	Reset line

- Tag Connect footprint.

Console ports

A dedicated USB micro AB-type port (J16) provides access to the two console ports of the ConnectCore 8M Nano system-on-module:

- i.MX 8M Nano Cortex A-53 serial debug port
- i.MX 8M Nano Cortex-M7 serial debug port

The USB port is routed directly to the FTDI FT232D bridge, which converts the USB bus into TTL UARTs:

Debug port	UART port
Cortex A-53	UART4
Cortex-M7	UART0

Note that UART4 is not connected to the FTDI chip by default. To access this UART, change the following resistors:

- Depopulate R152 and R154
- Populate R151 and R153

You can also access the UART ports at TTL level through the J17 connector:

Pin	Signal name	Description
1	3V3_DBG	3.3 V power rail
2	CONSOLE_TX	CPU console port transmission line
3	CONSOLE_RX	CPU console port receiver line
4	UART_M-CORTEX_TX	CORTEX microcontroller console port transmission line
5	UART_M-CORTEX_RX	CORTEX microcontroller console port receiver line
6	GND	Ground

Default console port settings

- Baud rate: 115200
- Data: 8 bit
- Parity: none
- Stop: 1 bit
- Flow control: none

USB recovery

The development board includes a dedicated USB micro AB-type port (J35) for recovery. This port detects when a cable is plugged in and automatically switches the USB1 bus of the CPU from its

default USB Host connection to the recovery port:

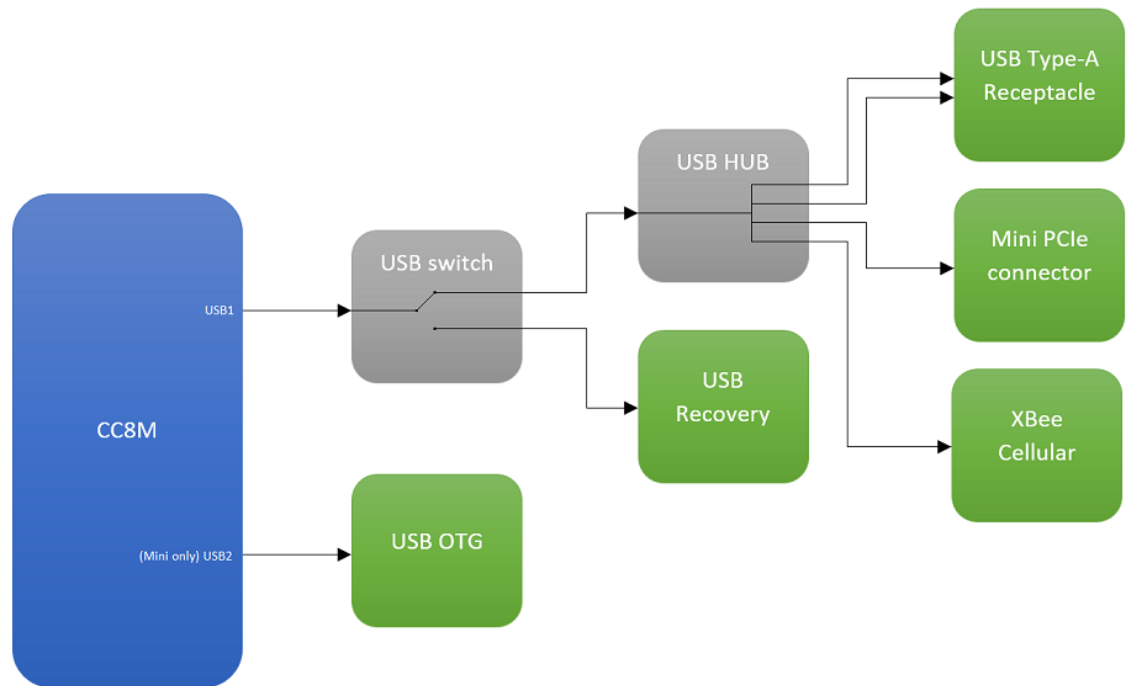

Note If J36 is closed, then the USB1 bus of the CPU is forced to be connected to the recovery connector J35.

Communication

Gigabit Ethernet

One 10Base-T/100Base-Tx/1000Base-T Ethernet interface is fully integrated in the board through the AR8031 Ethernet PHY. The bus is accessible through a RJ-45 connector with integrated link/activity LEDs, as specified in the following table:

Green LED	Yellow LED	Link/activity status
ON	OFF	10M/100M Link
BLINK	OFF	10M/100M Active
ON	ON	1000M Link
BLINK	ON	1000M Active

RS-485

The development board supports one RS-485 half-duplex bus, available on an expansion connector (J26):

Pin	Signal name	Description
1	3V3_SOM_EXT	3.3 V power supply
2	RS485_B	RS485 B line
3	RS485_A	RS485 A line
4	GND	Ground

UART3 is used for this purpose, together with the LTC2862 transceiver. You can connect a 120 Ω terminator resistor to the bus by closing J25.

Note UART3 is also connected to expansion header J45. To use these lines on this connector, remove resistors R291, R359, and R292 to avoid collision with the RS485 transceiver.

CAN

One CAN FD bus is available on the development board through connector J24:

Pin	Signal name	Description
1	5V	5 V power supply
2	CAN1_H	CAN high line
3	CAN1_L	CAN low line
4	GND	Ground

The i.MX 8M Nano CPU does not support any CAN interface, so the SPI3 bus of the CPU in combination with the MCP2517FD controller and the TCAN1042 transceiver are used for this purpose.

A 120 Ω terminator resistor can be connected to the bus by closing J23.

USB Host

Up to four USB Host interfaces are supported by the development board through the USB2514B USB hub:

- Two of the ports are available over a stackable dual USB A-type connector.
- One port is connected to the Mini PCI Express slot.
- One port is connected to the XBee Cellular socket.

Mini PCIe

The development board provides one Mini PCI Express socket (J19) supporting USB and I2C connection to the ConnectCore 8M Nano module. A micro SIM socket is also connected to the Mini PCI Express slot.

XBee

Two XBee sockets are populated on the development board. One of the sockets supports the XBee Cellular.

Multimedia

HDMI, LVDS, and MIPI displays

The ConnectCore 8M Nano System-on-Module supports only one MIPI-DSI display interface. On the ConnectCore 8M Nano Development Board, this MIPI-DSI display is managed so that three different display interfaces are supported, although only one of them can work at a time.

- **HDMI:** The Lontium LT8912B bridge is populated on the development board to adapt the MIPI-DSI interface to HDMI. This HDMI interface is available over a standard HDMI connector.
- **LVDS:** The SN65DSI83 bridge is also populated on the development board to adapt the MIPI-DSI interface to LVDS. This LVDS is available over a 20-pin connector (J32), also supporting backlight control and I2C touch controller:

Pin	Signal name	Description
1	3V3_SOM_EXT	3.3 V power supply
2	LVDS_TX0_N	Data pair 0 (-) line
3	LVDS_TX0_P	Data pair 0 (+) line
4	GND	Ground
5	LVDS_TX1_N	Data pair 1 (-) line
6	LVDS_TX1_P	Data pair 1 (+) line
7	GND	Ground
8	LVDS_TX2_N	Data pair 2 (-) line
9	LVDS_TX2_P	Data pair 2 (+) line
10	GND	Ground
11	LVDS_CLK_N	Clock pair (-) line
12	LVDS_CLK_P	Clock pair (+) line
13	GND	Ground
14	LVDS_TX3_N	Data pair 3 (-) line
15	LVDS_TX3_P	Data pair 3 (+) line
16	LVDS_PWM_OUT	Backlight PWM (connected to MCA_IO17)
17	LVDS_I2C_SCL	i.MX8M I2C2 bus clock line
18	LVDS_I2C_SDA	i.MX8M I2C2 bus data line
19	LVDS_IRQ_N	Interrupt line (connected to i.MX8M GPIO4_18)
20	5V	5 V power supply

- MIPI-DSI: the native MIPI-DSI interface of the SOM is available over a 15-pin connector (J30):

Pin	Signal name	Description
1	MIPI_EXT_DATA0_P	Data pair 0 (+) line
2	MIPI_EXT_DATA0_N	Data pair 0 (-) line
3	GND	Ground
4	MIPI_EXT_DATA1_P	Data pair 1 (+) line
5	MIPI_EXT_DATA1_N	Data pair 1 (-) line
6	GND	Ground
7	MIPI_EXT_DATA2_P	Data pair 2 (+) line
8	MIPI_EXT_DATA2_N	Data pair 2 (-) line
9	GND	Ground
10	MIPI_EXT_DATA3_P	Data pair 3 (+) line
11	MIPI_EXT_DATA3_N	Data pair 3 (-) line
12	GND	Ground
13	MIPI_EXT_CLK_P	Clock pair (+) line
14	MIPI_EXT_CLK_N	Clock pair (-) line
15	GND	Ground

MIPI-CSI camera

The development board provides a MIPI camera serial interface (MIPI-CSI) over a 15-pin connector (J29):

Pin	Signal name	Description
1	3V3_SOM_EXT	3.3 V power supply
2	MIPI_CSI_I2C_SDA	i.MX8M I2C2 bus data line
3	MIPI_CSI_I2C_SCL	i.MX8M I2C2 bus clock line
4	NC	Not connected
5	MIPI_CSI_RESET_N	Rreset line (connected to i.MX8M GPIO1_12)
6	GND	Ground
7	MIPI_CSI_CLK_P	Clock pair (+) line
8	MIPI_CSI_CLK_N	Clock pair (-) line

Pin	Signal name	Description
9	GND	Ground
10	MIPI_CSI_DATA1_P	Data pair 1 (+) line
11	MIPI_CSI_DATA1_N	Data pair 1 (-) line
12	GND	Ground
13	MIPI_CSI_DATA0_P	Data pair 0 (+) line
14	MIPI_CSI_DATA0_N	Data pair 0 (-) line
15	GND	Ground

By default, only two data lanes are supported. The additional two data lanes are available over an expansion connector (J28):

Pin	Signal name	Description
1	MIPI_CSI_DATA3_P	Data pair 3 (+) line
2	MIPI_CSI_DATA3_N	Data pair 3 (-) line
3	GND	Ground
4	MIPI_CSI_DATA2_P	Data pair 2 (+) line
5	MIPI_CSI_DATA2_N	Data pair 2 (-) line
6	GND	Ground

Audio

The Maxim MAX98089 audio codec manages the audio interface on the development board. The board provides the following audio functionality:

- 3.5 mm headphone jack
- 3.5 mm microphone jack
- x2 speaker outputs (left and right)
- x1 line-out output
- x2 line-in inputs

The speakers, line-out signals, and line-in signals are available over a 10-pin connector (J53):

Pin	Signal name	Description
1	LINE1_IN_R	Single-ended line input A1
2	LINE1_IN_L	Single-ended line input A2
3	LINE2_IN_R	Single-ended line input B1

Pin	Signal name	Description
4	LINE2_IN_L	Single-ended line input B2
5	LINE_OUT_R	Right line output
6	LINE_OUT_L	Left line output
7	SPKL_P	Positive left-channel class D speaker output
8	SPKL_N	Negative left-channel class D speaker output
9	SPKR_P	Positive right-channel class D speaker output
10	SPKR_N	Negative right-channel class D speaker output

Storage interfaces

MicroSD

A microSD socket (J18) is located on the top side of the board, next to the RJ45 connector. This interface is connected to the USDHC2 port of the i.MX8M Nano CPU.

User interfaces

User LED

Three LEDs are available on the development board: one green, one yellow, and one red. All of them are connected to SOM GPIOs.

User button

Two buttons are available on the development board, both of them connected to the SOM.